



## SUPPLIER MANUAL

### **FIDELTRONIK**

ul. Beniowskiego 1  
34-200 Sucha Beskidzka  
POLAND  
Phone: +48 33 874 98 00  
+48 33 874 98 01  
Fax: +48 33 874 13 77  
[www.fideltronik.com](http://www.fideltronik.com)

## 1 TABLE OF CONTENTS

<b>GENERAL REQUIREMENTS</b>	
<b>1</b>	<b>TABLE OF CONTENTS ..... 2</b>
<b>2</b>	<b>INTRODUCTION ..... 3</b>
<b>3</b>	<b>SUPPLIER SELECTION AND QUALIFICATION PROCESS ..... 3</b>
<b>4</b>	<b>ADVANCED PRODUCT QUALITY PLANNING ( APQP ) ..... 5</b>
4.1	PRODUCTION PART APPROVAL PROCESS ( PPAP ) ..... 5
4.1.1	SPECIFIC CUSTOMER REQUIREMENTS ..... 7
<b>5</b>	<b>CONFIRMATION OF ORIGINALITY AND COMPATIBILITY OF PRODUCTS ..... 7</b>
<b>6</b>	<b>IT SECURITY ..... 7</b>
<b>7</b>	<b>CLAIMS ..... 7</b>
7.1	SPECIALIZED LEVELS OF SUPPLY CONTROL ..... 8
<b>8</b>	<b>SUPPLIER EVALUATION AND DEVELOPMENT ..... 9</b>
8.1	SUPPLIER EVALUATION SYSTEM ..... 9
8.2	QUALITY AUDIT ..... 14
8.3	CORRECTIVE AND PREVENTIVE ACTIONS ..... 15
<b>9</b>	<b>PROCESS DOCUMENTATION AND SUPERVISING CHANGES ..... 16</b>
9.1	GENERAL REQUIREMENTS ..... 16
9.2	SPC AND SPECIAL CHARACTERISTICS ..... 16
<b>10</b>	<b>SUSTAINABILITY ..... 17</b>
10.1	STATUTORY AND REGULATORY REQUIREMENTS ..... 17
10.2	ENVIRONMENTAL PROTECTION ..... 17
10.2.1	GENERAL REQUIREMENTS ..... 17
10.2.2	COMPLIANCE WITH RoHS DIRECTIVE ..... 19
10.2.3	COMPLIANCE WITH REACH ..... 19
10.2.4	CONFLICT MINERALS ..... 20
10.2.5	SPECIFIC CUSTOMER REQUIREMENTS ..... 20
10.3	CODE OF CONDUCT ..... 21
10.4	HEALTH AND SAFETY OF WORK ..... 22
10.5	CONFIDENTIALITY AND INTELLECTUAL PROPERTY RIGHTS ..... 23
<b>11</b>	<b>SHIPPING OF GOODS AND INVOICES ..... 24</b>
<b>12</b>	<b>PACKAGING ..... 25</b>
12.1	REQUIREMENTS CONCERNING THE IDENTIFICATION ON PACKAGES ..... 26
<b>REQUIREMENTS IN RELATION TO PARTICULAR GROUP OF COMPONENTS</b>	
<b>13</b>	<b>CATALOGUE COMPONENTS ..... 30</b>
<b>14</b>	<b>PRINTED CIRCUIT BOARDS ..... 31</b>
<b>15</b>	<b>MAGNETIC COMPONENTS ..... 35</b>
<b>16</b>	<b>LOOMS ..... 36</b>
<b>17</b>	<b>ELECTRO-MECHANICAL AND MECHANICAL COMPONENTS ..... 37</b>
<b>18</b>	<b>FINAL PROVISIONS ..... 38</b>

## 2 INTRODUCTION

This document specifies the requirements that the Fideltronik supplier should meet. These Supplier Manual describe also Fideltronik specific requirements for particular group of components:

- Catalogue components (electronic, chemical and mechanical)
- Printed Circuit Boards
- Magnetic components
- Looms
- Electro-mechanical and mechanical components

## 3 SUPPLIER SELECTION AND QUALIFICATION PROCESS

### Definition

New supplier:

A new supplier is a company that has never conducted business with Fideltronik or a former supplier who has not supplied product to FT in the last three years. All new suppliers must be qualified before new business is awarded.

New Supplier Qualification Process:

Process of adding a new supplier to the Fideltronik Approved Supplier List based on the analysis of supplier's ability to perform according to the Fideltronik requirements included in the Supplier Manual.

### Supplier Vetting

#### 1. General requirements

**General Fideltronik requirements** are included in the **Supplier Manual** which is available on Fideltronik website: <https://fideltronik.com/new-supplier/>

Supplier shall confirm its ability to comply with those requirements by completing the **Supplier Questionnaire** and submitting it online on website: <https://fideltronik.com/new-supplier/> or by e-mail to the Fideltronik contact person.

The Mandatory part of the Supplier Questionnaire to be filled out is the "Supplier Profile" section. Any omissions or gaps in the section mentioned above will result in the rejection of the application.

**Confidentiality** - Fideltronik considers operations with suppliers as confidential and they are covered by professional secrecy as referred to in section 10.5 of this Supplier Manual.

At the request of Fideltronik supplier shall confirm its ability to comply with the statements of the Non-Disclosure Agreement (NDA) by signing and returning it to Fideltronik via email to the Fideltronik contact person and posting it to Fideltronik's HQ address. A NDA document is available to download from the Fideltronik website : <https://fideltronik.com/new-supplier/>

#### 2. Data collection and analysis

Verification of the collected information in terms of:

- assessment of the Supplier's ability to meet Fideltronik's requirements and
- matching the Supplier to the Development Strategy.

### 3. Adding Supplier to the “Identified Supplier List”

If the Supplier meets Fideltronik requirements and suit our Company’s supply base development strategy, they can be added to the “Identified Supplier List”.

## Supplier Qualification

### 1. Needs analysis

Depending on the needs deriving from new business opportunities as well as the Company’s supply base development strategy, a list of suppliers to be considered in the subsequent steps of the process is created.

### 2. Supplier’s capability analysis

Review of submitted quotes and other information received from vendors. At this stage the Total Cost of Ownership is taken into consideration for all quotes provided.

Analysis of the Supplier’s ability to meet Fideltronik’ requirements and comparison of the collected information. Based on the results of the conducted analysis the decision on proceeding to further steps of the qualification process is made.

### 3. Request for Supplier Self-Assessment

Supplier shall complete and return to Fideltronik the self-assessment section of the Supplier Questionnaire: Eng. FDMS-23-2133, (“Std Check List” sheet, column D) - available for download from the Fideltronik website: <https://fideltronik.com/new-supplier/>

Fideltronik can also require from chosen supplier completing ESD Form (FDMS-37-121).

### 4. Supplier Audit

If required, a supplier audit is conducted based on the criteria included in the Supplier Questionnaire and/or ESD Form.

### 5. Adding a new supplier to the Approved Vendor List

In cases where the result of a conducted qualification process is positive, based on the individual buyer’s decision, Supplier is added to the Approved Vendor List.

## 4 ADVANCED PRODUCT QUALITY PLANNING ( APQP )

APQP – this is a defined process for product development. According to the AIAG ( Automotive Industry Action Group ), the purpose of APQP is "to produce a product quality plan which supports development of a product or service satisfying the customer." The process is described in the AIAG manual 810-358-3003.

In other words this is a process for establishing, meeting, and exceeding quality objectives. Supplier APQP teams must include a cross functional team consisting of members from every area/department in the organization as well as the appropriate subcontractor and Fideltronik personnel. APQP is required for the following scenarios:

- During the development of new processes and or products
- Prior to significant changes to process and/or products as determined by Quality Department
- Prior to tooling being transferred to new producers or facilities.

### 4.1 PRODUCTION PART APPROVAL PROCESS ( PPAP )

*Based on AIAG PPAP Fourth Edition*

**PPAP** is used to establish confidence in suppliers and their processes, by demonstrating that:

- Customer design record and specifications and other requirements are properly understood by the supplier.
- Process proposed by the supplier has the potential to produce a product consistently meeting these requirements with defied production rate.

#### **When is PPAP required?**

Full approval from the Customer regarding product approval must be obtained by the Supplier for:

- A new part or product (i.e., a specific part, material, or color not previously supplied to the specific Customer).
- Correction of a discrepancy on a previously submitted part.
- Product modified by an engineering change to design records, specifications, or material.
- Any situations required by the Customer.

#### **The 5 Submission Levels**

The items and/or records specified by the level requested by the customer must be submitted by the supplier:

*Level 1* – Warrant only (and for designated appearance items, an Appearance Approval Report) submitted to the Customer.

*Level 2* - Warrant with product samples and limited supporting data submitted to the Customer.

**Level 3 - Warrant with product samples and complete supporting data submitted to the Customer.**

*Level 4* - Warrant and other requirements as defined by the Customer.

*Level 5* - Warrant with product samples and complete supporting data available for review at the supplier's manufacturing location.

## Retention Requirement Table / Submission Level

Requirement	Level 1	Level 2	Level 3	Level 4	Level 5
1. Part Submission Warrant	R	R	R	AR	R
2. Design records	-	R	R	AR	R
3. Approved Engineering Change Documentation	-	-	R	AR	AR
4. Customer Engineering approvals	-	-	R	-	-
5. Design FMEA	-	-	AR	AR	AR
6. Process Flow Diagrams	-	-	R	AR	R
7. Process FMEA	-	-	R	AR	R
8. Control Plan	-	R	R	AR	R
9. Measurement System Analysis Studies	-	AR	R	AR	R
10. Dimensional Results	-	R	R	AR	R
11. Material, Performance, Test Results	-	AR	R	AR	R
12. Initial Process Study (Cpk) Capability Studies	-	AR	R	AR	R
13. Accredited Laboratory Documentation	-	-	R	AR	R
14. Appearance Approval Report (AAR), if applicable	AR	AR	AR	AR	AR
15. Sample Product	-	R	R	AR	R
16. Master Sample	-	-	R	-	R
17. Checking Aids	-	-	R	AR	R

R – Required for PPAP submission

AR – Documents on a case by case basis are marked AR for "As Requested"

' - ' – Not Required

In addition, along with appropriate documentation to the required PPAP level by Fideltronik, the following is necessary such as providing a packing instruction were any changes in the packing method without the permission of Fideltronik is prohibited.

For automotive products Fideltronik also requires submitting material data into the International Material Data System (IMDS), ID:40641. All changes in the product, that influence the material composition requires resubmission of data into the IMDS.

Any section that is not applicable must be included in the PPAP submission with a placeholder showing that this section is not applicable. This is to ensure no sections have been missed. Fideltronik will review the supplier PPAP submission using the PPAP submission checklist with any deficiencies being sent back to the supplier for resubmission.

If a Supplier cannot meet the PPAP requirements by the required date the Prototype and Interim approval form will be required outlining the issues with new promise dates.

Approval of PPAP by Fideltronik is confirmed in the "Item technical specification" (approval date for a given item) attached to the iSupplier Portal or sent by e-mail.

Note:

In the case of the requirement to provide samples (see point 15 of PPAP) they should be specifically identified on the outside of the package e.g. "ENGINEERING SAMPLES".

## 4.1.1 SPECIFIC CUSTOMER REQUIREMENTS

In the case of Specific Customer Requirements or when the client determines alternative qualification criteria other than the ones stated below the Supplier is obligated to present data ( reports, research results) which confirms fulfillment of the new requirements to Fideltronik upon request.

## 5 CONFIRMATION OF ORIGINALITY AND COMPATIBILITY OF PRODUCTS

The Supplier is obliged to ensure and, if necessary, provide evidence that all products delivered to the Customer are original (i.e. they were manufactured by manufacturers specified by Fideltronik) and compliant with requirements.

The supplier is also obliged to plan, implement and control processes appropriate to the organization and the product to prevent the use of counterfeit or suspected counterfeit parts.

Fideltronik carries out internal inspection of purchased products based on its own procedures and reserves the right to carry out quality control of products and processes at the supplier (performed for Fideltronik).

Fideltronik' s internal inspection and any control at supplier's does not remove supplier's responsibility for compliance of supplied products with the requirements set forth in the technical documentation, this Supplier Manual and the order.

## 6 IT SECURITY

Fideltronik requires from its suppliers:

- having a policy and procedures regarding IT security
- having security procedures against cyberattacks and data loss (security against installation of unauthorized software, antivirus software, password management policy, etc.)
- ensuring that the IT systems in the organization operate in accordance with the law and best practices (e.g. appropriate licenses for the software used)
- ensure that in the event of failure, loss or destruction of operating equipment (applications, data), continuous access to the systems will be provided

## 7 CLAIMS

In the case when the products delivered by supplier do not comply with applicable legal requirements, customer specific requirements, technical documentation, order specification and the requirements of this Supplier's Manual, Fideltronik will file a complaint.

Complaints are subject to both non-conformities resulting from the production process, distribution process and non-compliance of materials and components used to manufacture these products.

The complaint is sent by e-mail to the supplier.

For each complaint is assigned a Fideltronik reference number (Non-Conformance Number: NZG-XXXXX), which is included in the title of the complaint and must be kept in the title of all correspondence regarding a given complaint.

The supplier shall confirm **within 48-hrs (in urgent issues 24-hrs)** receipt of the claim notification, provide the RMA number (if necessary) and necessary immediate actions (3D) to protect Customer needs (e.g. replacement of goods, sorting activities to secure continuity of supply, etc.).

Additionally, **within 10 days** the supplier shall confirm the claim and pick up the rejected goods (if not agreed otherwise). Lack of supplier confirmation within 10 days will be considered by Fideltronik as an acknowledgment of the claim - in this case Fideltronik reserves the right to utilise the defective goods at the supplier's expense and issuing an invoice or debit note for the equivalent value.

If the replacement of the goods (with a defect-free one) has been agreed, the replacement must be described with the Fideltronik Non-Conformance Number (NZG-XXXXX) and the name and surname of the person reporting the non-conformance.

Completed 8D report should be provided to Fideltronik within **30 days** from the date of the claim notification. For specific issues or customer requirements ( e.g. for automotive projects ) or with any issues, 8D completion time may be shorter. Supplier will be informed in advance about those exceptions.

After detecting non-conformance related to the delivered goods, Fideltronik reserves the right to charge the supplier with a complaint handling cost of **EUR 100** for each complained item (or its equivalent according to the National Bank of Poland exchange rate on the invoicing day) as well as direct costs incurred by Fideltronik as a result of detected non-conformance (e.g. segregation, rework, repair, costs of assembled products, costs of recall, etc.). Moreover, Fideltronik may claim compensation on general terms.

The supplier may be charged with cost of complete, assembled product in case when the failures cannot be removed (while maintaining compliance with all other product requirements) or when the customer does not authorize it.

In case when supplier is not able to protect the continuity of Fideltronik production e.g. by providing replacement batch, repair or segregation affected parts within a specified (by Fideltronik) time, Fideltronik is obligated to charge the supplier for the cost of any additional actions (if they are possible) performed by Fideltronik (to protect Customer needs e.g., sorting, repair etc.) using the following calculation rates (unless another Fideltronik document specifies otherwise):

- Hourly rate of production worker in case of easy to identify and check problem (e.g., sorting):  
20 EUR
- Hourly rate in case when extra tooling, qualification and/or approval of the component by Product or Quality Engineer is needed (e.g. sorting, rework):  
40 EUR

## 7.1 SPECIALIZED LEVELS OF SUPPLY CONTROL

### **Concern the suppliers supplying the products to automotive projects.**

Fideltronik reserves the right to present suppliers with a Controlled Shipping level: CSL I or CSL II.

When Fideltronik presents a supplier with a status be that CSL I or CSL II, the supplier will be informed with a special information letter. Once such a letter is obtained the supplier is obliged to put into action a specialized supply control process which is compliant with the principles below:

**CSL I:** requires 100% control in the suppliers manufacturing plant on a separate post (not recognized by the standard control process). This inspection process is imposed to ensure that Fideltronik is protected



from receiving non-compliant parts. A supplier who attains control level CSLI is also required to inform Fideltronik of the result of the inspection that took place up until the aforementioned CSL I is lifted.

**CSL II:** requires 100% control, which is to be carried out by a third party. Fideltronik decides on the third party as well as the place where the inspection takes place. Financial responsibility for the inspection lies with the supplier.

At the moment when the supplier or third party finds nonconformances the special status prolongs by a previously agreed period.

Lifting of the CSL status on the supplier is done by Fideltronik with a special information letter. This in turn means that all specialized control processes, applicable for the assigned CSL level can be lifted.

#### **Supplier responsibility:**

- Acknowledging receipt of notification and thereupon taking immediate action.
- In the case of control level II:
  - Sending orders to units fulfilling the inspection.
  - Presenting the appropriate documents and equipment required to do a correct inspection
- Continuing the control activity until it is lifted by Fideltronik.
- Ensuring proper identification of the item carrying the special control status during final inspection.
- Determining the root cause and implementing irreversible corrective actions.
- Communicating an action plan and its status to Fideltronik in an agreed format and within specific iterations.

## **8 SUPPLIER EVALUATION AND DEVELOPMENT**

### **8.1 SUPPLIER EVALUATION SYSTEM**

In order to achieve complete customer satisfaction as well as to deliver best in class quality and highest level of service Fideltronik set up measurable quality objectives helping us to monitor and continuously improve our supplier's performance.

Our expectations towards suppliers are not different from those of our Customers. We focus on Suppliers who are committed to develop in the areas such as optimal performance in product quality, on-time delivery and cost as well as implementing continuous improvement in order to help encourage mutual growth.

#### **Definition**

The assessment of suppliers is conducted quarterly based on Key Performance Indicators. Suppliers are categorized for evaluation on the basis of their quarterly turnover (90 %).

For a chosen group of Suppliers, evaluation is carried out each month. Suppliers assigned to such a group can be indicated by the Customer or can be associated with the appropriate project where this requirement is obligatory.

#### **Indicators**

Required information for the Supplier evaluation is gathered in Fideltronik computer system.

Suppliers are evaluated according to the following indicators, which are divided into three main categories such as Quality, Delivery and Costs:

## 1. QUALITY PERFORMANCE

Information gathered by the Fideltronik computer system.

Scoring criteria:

- **PPM Level** / Level of delivery defectiveness – The PPM index is calculated using the equation below:

$$PPM = \frac{N_w}{N_d} \bullet 1000000$$

where:

Nw – Quantity of defective components during a given time

Nd – Quantity of items delivered in that given time

### IMPORTANT:

Suppliers are committed to deliver parts free from defects as ultimate PPM's target is 0.

#### - Customer disruptions

Concerns the reported non-conformance with high or critical priority reported from the client, along with the returns from the market.

Critical Priority: Nonconformances related to security issues and/or market returns

High Priority: Nonconformances influencing product specification or main fit and function features, concerning serial problems with high risk of market returns.

#### - Production disruptions

Applies to non-conformance with high or critical priority (as above) noted during entry inspection or production

#### - 8D response time

Number of 8D reports not provided within the 30 day term.

#### - Reoccurrence

Number of repeated problems in a given time period according with the below time period and criteria.

Time period: 1 year

Reoccurrence criteria: supplier, part number, NCR code

- **Environmental, Health and Safety incidents** (Incidents that affect/carry risk to the environment and / or the Occupational Health and Safety of employees)

## 2. LOT ACCEPTANCE RATE

Information collected by Fideltronik computer system.

Nonconformance caused by failing to meet Fideltronik's requirements related to logistics, which prevents the acceptance of goods on the system or delays admission of parts to the warehouse

For example:

- Delivery of not ordered goods,
- Not registered dispatch confirmation (ASN, ASBN),
- Lack of customs import documents of imported goods,

## 3. DELIVERY PERFORMANCE

Information gathered by the Fideltronik computer system .

Scoring Criteria:

### **- On time delivery**

Measurement is made with respect to the promise date confirmed by the Supplier ( ang. Pro-mise Date ). Delivery is deemed to be supplied on time when the goods are delivered to the client's warehouse: 5 days in advance, 0 days later.

### **- Incidents of premium freight**

Number of registered premium freight transports due to fault of the Supplier.

Premium freight transports are connected with extra costs or charges incurred additional to contracted delivery. This can be caused by method, quantity, unscheduled or late deliveries, etc.

## **4. AVERAGE LEAD TIME**

Information collected by Fideltronik computer system.

Indicator determines the number of days between issuing purchase order to goods arriving and admission into Fideltronik warehouse

## **5. ROLLING PO PRICE SAVING RATE**

Information collected by Fideltronik computer system .

The system compares the average purchase price in the current quarter/month with the average price from the previous year.

## **6. ELECTRONIC INVOICES**

Information collected by Fideltronik computer system.

Indicator determines percent of invoices registered in the customers computer system through I-supplier portal or EDI.

## SCOPE OF SCORING

<b>QUALITY</b>	<b>QUALITY PERFORMANCE</b>	
	Score definition	Target
	<p><b>PPM level</b>                      &lt;250ppm (8 points)                      251-1000ppm (5 points)                      1001-2000 (2 points)                      &gt;2000ppm (0points)</p> <p><b>Customer disruptions:</b>                      No Incident (4 points)                      Noted Incident (0 points)</p> <p><b>Production disruptions:</b>                      No Incident (2 points)                      Noted Incident (0 points)</p> <p><b>8D response time :</b>                      8D response delivered on time (2points)                      8D response delivered after 30 days (0points)</p> <p><b>Reoccurrence</b>                      Reoccurrence not registered (2 points)                      Reoccurrence registered (0 points)</p> <p><b>Environmental, Health and Safety Incidents</b>                      No Incident (2 points)                      Incident occurs (0 points)</p>	<b>20p</b>
<b>LOT ACCEPTANCE RATE</b>		
Score definition	Target	
<p>2% &lt; 10 points                      6% &lt; 5 points ≤ 2%                      0 points ≤ 6%</p>	<b>10p</b>	

<b>DELIVERIES</b>	<b>ON TIME DELIVERY</b>	
	Score definition	Target
	<b>On time delivery:</b> 96% < 12 points 93% < 8 points ≤ 96% 90% < 4 points ≤ 93% 0 points ≤ 90%  <b>Incidents of premium freight:</b> No Incident (3 points) Noted Incident (0 points)	<b>15p</b>
	<b>AVERAGE LEAD TIME</b>	
<b>COSTS</b>	Score definition	Target
	15 points ≤ 14 days 14 days < 10 points ≤ 28 days 28 days < 5 points ≤ 56 days 0 points ≤ 56 days	<b>15p</b>
	<b>ROLLING PO PRICE SAVINGS RATE</b>	
	Score definition	Target
4.5% < 25 points 3.5% < 20 points ≤ 4,5% 2.5% < 15 points ≤ 3.5% 1.5% < 10 points ≤ 2.5% 0.5% < 5 points ≤ 1.5% 0 ptk ≤ 0.5	<b>25p</b>	
<b>COSTS</b>	<b>ELECTRONIC INVOICES</b>	
	Score definition	Target
	98% < 15 points 95% < 10 points ≤ 98% 90% < 5 points ≤ 95% 0 points ≤ 90%	<b>15p</b>

Analysis of all suppliers is made according to the form, statuses are given according to the scoring from the following table.

SCORE	SCORE DEFINITION	STATUS
71pkt – 100pkt	The supplier meets Fideltronik requirements on a satisfying level. Cooperation can be continued and further developed. Possible precautions can be undertaken to continuously improve cooperation.	<b>SATISFACTORY</b>
41pkt – 70pkt	The supplier meets Fideltronik's requirements with some defaults. There is potential to improve. Fideltronik reserves the right to require corrective and/or preventive measures in certain cases to which the supplier will be informed.	<b>ACCEPTED</b>
0pkt – 40pkt	The supplier does not meet Fideltronik's requirements. Critical non-conformances which occur should be immediately eliminated. The supplier should, in cooperation with Fideltronik, immediately define corrective actions and carry them out in an acceptable time (TEMPORARY ACCEPTED). In case of the absence of co-operation from the supplier side the Commodity Buyer takes action aimed at eliminating the supplier (TO BE ELIMINATED).	<b>TEMPORARY ACCEPTED and TO BE ELIMINATED</b>

## SUPERVISION OF APPROVED SUPPLIER LIST

The list is updated by the Commodity Buyer, and looked through comprehensively once per quarter after the quarterly suppliers evaluation.

## 8.2 QUALITY AUDIT

During cooperation with approved suppliers or during the process of new supplier qualification Fideltronik can demand to conduct a quality audit at the supplier.

Audit is usually conducted on the basis of the audit questionnaire previously sent and filled out by the supplier. A compliance with the customer's requirements, technical documentation, with right norms, standards and procedures is confirmed.

With an audit result, there is a report in which observations, remarks and areas for improvement are included. After the audit the supplier is obliged to take corrective actions according to plan described in point 8.3.

Access rights for Fideltronik, its customers, auditing organizations and other regulatory authorities to relevant areas of the facilities and to relevant documented information at each level of the supply chain must be ensured by the supplier.

## 8.3 CORRECTIVE AND PREVENTIVE ACTIONS

### Definition

Corrective and preventive actions are taken by suppliers to contribute towards the improvement of the organization as well as to prove constant process-improvement. Actions appropriately addressed shall influence reduction in the number of gaps or complaints, increase productivity, increase sales volume, reduce operating costs, etc.

### Claims

In case of defects detected in delivered products, irrespective of the claim procedure, Fideltronik requires presentation of the corrective action plan in the 8D form.

Specific information concerning the claim process and terms of corrective action implementation are included in point 7.

### Corrective actions supervisory

Fideltronik Quality Department can require presentation of evidence of corrective and preventive actions and perform their verification during the audit visit.

The received 8D report and the evidence provided is put in Fideltronik's database under the given nonconformance standing as ground for its closing. Effectiveness of taken actions is verified on the basis of inspection result of the next received delivery.

### Supplier evaluation

The supplier evaluation is sent to suppliers by e-mail.

Together with the evaluation, a form is sent to the supplier in which a proposal for corrective actions (if required) should be completed along with the deadline for their implementation.

The form, supplemented with corrective actions, should be returned to Fideltronik within 15 business days from the date of receipt of the assessment result (unless otherwise agreed).

### Supplier Audit

After the audit a report is sent to the supplier with marked improvement areas. The supplier is obliged to provide the corrective actions within 15 working days from receiving the report. Fideltronik can require evidence from taken actions and conduct a verifying audit.

For areas marked in the audit report as "M" (Mandatory), which were evaluated as high risk as a result of the audit, Fideltronik requires immediate corrective actions. No actions in these areas within the deadline confirmed by Fideltronik may result in suspension of cooperation with the supplier or, in the case of a new/potential supplier, no cooperation start.

**When a supplier does not take corrective and preventive actions** - does not express the willingness to improve and develop its processes, Fideltronik may take steps to remove the supplier from Approved Vendor List. In such a case, the supplier is given the status "to be eliminated" and then "phase out".

## 9 PROCESS DOCUMENTATION AND SUPERVISING CHANGES

### 9.1 GENERAL REQUIREMENTS

The supplier is obliged to have a documented manufacturing process. Fideltronik recommends usage of the following documents:

- FLOW-CHART
- CONTROL PLAN

Above documents should be available upon Fideltronik request.

The Control Plan can be based on recommendations from the APQP referential textbook (Advanced Product Quality Planning) published by AIAG. Fideltronik Document forms are available at: <https://fideltronik.com/our-supplier/> in the Polish version as "PPAP dokumenty do pobrania" or in the English version as "PPAP forms to download".

The supplier is obliged **to inform Fideltronik in advance** about planned changes in following areas:

- technological process
- applied materials
- manufacturing sites ( specifically applied, but not limited to PCB manufacturers),
- process flow chart

Please note that they require Fideltronik' s approval.

Technological changes should be reflected in such documents as the Flow Chart and Control Plan which should be sent immediately to Fideltronik (PPAP package – described in point 4 ).

Fideltronik reserves a right to refuse proposed changes or request to provide additional data or/and samples supporting this change.

A supplier is obliged to give the date when a change in the technological process was implemented and any changes to the purchase order of the delivery should be mentioned within. It is aimed at the identification of supplier changes and their influence on the quality of the product.

In case of implementing unauthorized changes all costs incurred by Fideltronik and/or our Customers will be the sole responsibility of the Supplier.

### 9.2 SPC AND SPECIAL CHARACTERISTICS

#### Definition

SPC -Statistical Process Control – statistical method of quality management which enable the objective assessment whether the given process is stable or start to behave out of standard.

The supplier is obliged to guarantee the necessary training of appropriate staff on his own and the measurement equipment at his plant with respect to SPC (Statistical Process Control).

Determining specific requirements, for supervising the process and reporting quality results by the supplier to Fideltronik, for chosen products should be held in the way shown below.



## **Cpk measurements of special and critical characteristics**

The supplier is obliged to perform measurements of special and critical parameters in every delivery to Fideltronik shown in the technical documentation and/or specification.

Measurement results have to be documented. Cpk values must meet the condition:

$$\text{Cpk} \geq 1.67$$

Cpk  $\geq$  1.33 is allowed provided that the supplier conducts documented activities aimed at achieving the target value of 1.67.

### **Measuring document**

The supplier is obliged to make Cpk measurements of special and critical characteristics on his own for every batch.

The document confirming the compliance with specific requirements of the customer should contain :

- measurement results
- measurement method
- material used

The supplier is obliged to archive this document of the minimum of 5 years and to make it available at the customer's request.

## **10 SUSTAINABILITY**

### **10.1 STATUTORY AND REGULATORY REQUIREMENTS**

Supplier is obligated to ensure that their products, processes, and services conform to the current applicable statutory and regulatory requirements in the country of receipt, the country of shipment, and the customer-identified country of destination, if provided.

If Fideltronik defines for specific products, that are subject to statutory or regulatory requirements, special control actions then the supplier should ensure that they will be implemented and maintained.

For defined by Fideltronik statutory and regulatory requirements and special features of the product and process it is required that the supplier should communicate this further along the supply chain until reaching the appropriate manufacturing place.

### **10.2 ENVIRONMENTAL PROTECTION**

#### **10.2.1 GENERAL REQUIREMENTS**

In compliance with Fideltronik's environmental policy the Supplier, when delivering products and services, shall be obliged to follow the principles below:

#### **Reduce the amount of Styrofoam in wrappings**

Styrofoam is very difficult to recycle and has a notably more harmful environmental impact (as waste) than other wrappings (wood, cardboard or metals).

Fideltronik recommends to reduce as much as possible the use of Styrofoam in wrappings and to replace it with materials with lower environmental impact (cardboard, steel, wood) or use returnable wrappings.

## Use of returnable wrappings

Fideltronik recommends, where possible, use of returnable wrappings in order to reduce environmental impact of wrapping materials and cut the unnecessary cost (liquidation of collective wrappings).

**According to the environmental Fideltronik policy, suppliers are obliged to meet the following requirements:**

- Everywhere where it is required, deliver the Material Safety Data Sheet of dangerous substances
- The supplier is fully responsible for the receipt upheld by law in the treatment, storage, return and utilization of dangerous materials in his plant which is necessary to produce and provide products to Fideltronik.
- Suppliers performing services in Fideltronik premises are obliged to segregate waste according to applicable rules.

During the supplier qualification process Fideltronik takes environmental aspects into consideration. The supplier is obliged to offer environment-friendly raw materials, including design, material selection, manufacturing processes and delivery in accordance with LCA (Life Cycle Analysis).

Additional information:

Ordinance of the Minister of Economy and Labour dated 27 Mar. 2007 on specific requirements concerning use of environment unfriendly substances in electronic and electrical devices (Journal of Laws 2007 No. 69 item 457).

## MATERIAL DECLARATIONS

Fideltronik, in accordance with its environmental policy and taking into account the requirements of legal regulations as well as the requirements of its customers, may request from the supplier Material Declarations confirming compliance with them (e.g. taking into account the use of selected elements, the place of origin of given materials or their components).

Declarations should contain a detailed description of the measuring methods and results of measurements and be updated at least once a year.

## DEFORESTATION REGULATION

In accordance to Regulation (EU) 2023/1115 of the European Parliament and of the Council of 31 May 2023 on the making available on the Union market and the export from the Union of certain goods and products related to deforestation and forest degradation and repealing Regulation (EU) No 995/2010 , **the Supplier has an obligation:**

- to ensure that the products it distributes do not contribute to deforestation and that no illegal deforestation practices are associated with the production or sourcing of raw materials throughout the supply chain
- at Fideltronik' s request, provide evidence of compliance with the above. Requirements

## 10.2.2 COMPLIANCE WITH RoHS DIRECTIVE

In relation to the Directive 2011/65/EU on the restriction of the use of certain hazardous substances in electrical and electronic equipment with amendment 2015/863/EU, **to the first shipment** and on request, Fideltronik requires from a Supplier a declaration of compliance of supplied components with the requirements of the RoHS directive, RoHS tests result or Full Material declaration to the following e-mail: [rohs@fideltronik.com](mailto:rohs@fideltronik.com).

Declaration should involve all materials from which the product is manufactured as well as the materials used in the manufacturing process (including operating materials).

Moreover if it is possible the supplier should mark on the packaging (in every delivery to FT) that the product is RoHS compliant.

## 10.2.3 COMPLIANCE WITH REACH

According to requirements of the Regulation (EC) No. 1907/2006 of the European Parliament and of the Council concerning the Registration, Evaluation, Authorization and Restriction of Chemicals (REACH) Fideltronik as the downstream user require:

- Conformity of supplied components/materials with REACH (including the Candidate List of SVHC, Annex XIV and Annex XVII).

If the supplied component/material contains a substance from the SVHC Candidate list (the list available at <http://echa.europa.eu/web/guest/candidate-list-table> above 0.1% weight by weight in the product, supplier is required to inform immediately Fideltronik and provide name of the substance and its % contents in the supplied component/material.

From 5<sup>th</sup> of January 2021, companies supplying articles containing substances of very high concern (SVHC) on the Candidate List in a concentration above 0.1% weight by weight on the EU market have to submit information on these article to The European Chemicals Agency (ECHA), into the SCIP database. SCIP is the European database for information on **S**ubstances of **C**oncern **I**n articles as such or in complex objects (**P**roducts) established under the Waste Framework Directive (2008/98/EC). Reporting into SCIP is mandatory for all companies supplying articles on the EU market. The information in the database is then made available to waste operators and consumers. On request supplier is obliged to provide SCIP number for supplied part.

Fideltronik requires REACH statement to the first shipment or when is duty according to the Article 33 of REACH regulation and on request to the following e-mail: [rohs@fideltronik.com](mailto:rohs@fideltronik.com).

- Conformity from all suppliers of the supplied Material Safety Data Sheet (MSDS) with the Article 31 of the REACH Regulation.

The records relate, among the others to:

- An obligation of delivering and informing customers about the Material Safety Data Sheet updates. The actualization includes also the obligation to adjust the MSDS in accordance with the requirements of the Regulation.

Basing on above in case of any amendment to the Material Safety Data Sheet or the delivered product the supplier is obliged to announce this to Fideltronik with immediate effect and immediately provide a new Material Safety Data Sheet.

**Material Safety Data Sheets should be sent to the responsible Buyer or to the address of Fideltronik's headquarter, addressed to a specific person.**

- Material Safety Data Sheet should be written in the official language of the State in which the substance or mixture is placed on the market, in our case, in Polish.

- Fideltronik Group requires from its suppliers to providing Material Safety Data Sheet, also for

substances that do not meet the criteria for classification as hazardous.

On June 26, 2020, Commission Regulation (EU) 2020/878 of June 18, 2020 amending Annex II to Regulation (EC) No 1907/2006 of the European Parliament and of the Council on registration, evaluation, authorization was published in the Official Journal of the EU and applicable restrictions on chemicals (REACH).

From January 2023, safety data sheets should be developed in accordance with the latest safety data sheet template set out in Regulation 2020/878/EU.

Manufacturer / Supplier who fail to comply with the information above are, in accordance with the relevant legislation, subjected the penalty of a fine.

## 10.2.4 CONFLICT MINERALS

As a manufacturer of electronic and mechanical assemblies (EMS), we are aware of our obligations under laws relating to using Conflict Minerals: tin, tantalum, tungsten, gold (3TG Minerals) and requirements to mica and cobalt originated from conflict-affected and high-risk areas.

The legal requirement include specifically the Dodd-Frank Wall Street Reform and Consumer Protection Act, Section 1502 and regulation 2017/821/EU - laying down supply chain due diligence obligations for Union importers of tin, tantalum and tungsten, their ores, and gold originating from conflict-affected and high-risk areas.

On request of our Customers we are working with our direct Suppliers within our supply chain to determine the origin of 3TG Minerals, mica and cobalt and to collect information about their compliance with the regulations and requirements.

Fideltronik uses the OECD Guidance and the Responsible Minerals Initiative reporting templates to document its compliance efforts: CMRT (Conflict Minerals Reporting Template) for 3TG Minerals and EMRT (Extended Minerals Reporting Template) for cobalt and mica reporting

Fideltronik requires that its Suppliers:

1. Commit to being/ becoming 'Conflict-free' - meaning that such Suppliers source materials only from conflict-free smelters. Suppliers are also responsible for passing the same requirements on to their supply chain.
2. Have a system or methods in place to ensure that parts supplied to Fideltronik are "Conflict-free".
3. On request, provide to Fideltronik completed declarations (using the Responsible Minerals Initiative reporting templates) evidencing such commitment and documenting the countries of origin from which the Supplier directly or indirectly sources 3TG Minerals, mica and cobalt.

## 10.2.5 SPECIFIC CUSTOMER REQUIREMENTS

Apart from requirements included in above points the supplier is obliged at Fideltronik request to provide data (reports, findings) confirming the fulfilment of the customer requirements.

## 10.3 CODE OF CONDUCT

Fideltronik will consider cooperating only with suppliers which act ethically, respect Human rights and conform to the following rules:

### **Discrimination**

All employees shall be treated rightfully regardless of their job responsibilities and business position. Similar rules apply to relations with people outside the company. The employees shall not discriminate others on the basis of their age, gender, race, nationality, religion, disability, origin, marital status; offend coworkers or other people verbally, physically or in any other way; sexual harassment or mobbing shall not take place; an employee shall not spread hearsay or false information about coworkers or other people.

### **Openness and communication**

Supplier promotes proper communication amongst employees and contractors based on openness and respect. Every employee should report his or her remarks to the supervisor. The company places great emphasis on honesty, not only towards coworkers but clients, suppliers and itself.

### **Remuneration**

Payment is distributed in accordance with labor law provisions.

### **Children and young workers**

Supplier does not employ children or support the use of child labor. That excludes initiatives such as government approved youth training schemes (e.g. work-experience programs).

The minimum age of employment shall be 16 years of age. The company does not use employees under 18 years of age for hazardous work.

### **Forced labor**

The Uyghur Forced Labor Prevention Act (U.S. Public Law No. 117-78), also known as the UFLPA, mandates strict compliance with guidelines designed to prevent forced labor, particularly in the context of populations from the Xinjiang Uyghur Autonomous Region, or Xinjiang in People's Republic of China. Given the seriousness of this issue and Fideltronik's commitment to ethical practices, we require all suppliers in our supply chain to comply with these standards.

### **Competition and antitrust law**

Supplier supports the quality and price competition. The Company is committed to conducting business in an **open and honest manner. Complying with antitrust norms and regulations on fair competition requires that employees abide to the following rules:**

- a) do not accept, disclose or use competitive information in breach of a confidentiality agreement between a third party and competitors
- b) do not accept any competitive agreements to fix prices, share the market, etc.
- c) do not abet clients to obtain products or services that do not meeting their needs
- d) provide client with detailed and solid information on quality, functions and availability of offered products

### **Corruption and Bribery**

Company's achievements, reliability and quality of products and services constitutes a base for business relations. Both workers and contractors are not allowed to affect a decision-making person by unlawful financing, ravishment or doing favors with the intention of influencing a third party to obtain or retain business or a business advantage, or to reward the provision or retention of business or a business advantage, or in explicit or implicit exchange for favors or benefits.

Company employees are obliged not to offer any bribes either financial, material or any other in order to gain any commercial, contractual, regulatory or personal advantage, especially given in secret. Gifts should not be offered to, or accepted from, government officials or representatives, contractors or their

relatives when they aim at "facilitation" or expenditure of a routine procedure; with the expectation or hope that a business advantage will be received, or to reward a business advantage already given.

### **Donations and grants**

Financial grants may only be awarded to the party officially permitted to generate surplus revenues (like charitable or non-profit organizations), and the support may be provided in compliance under law in force. Moreover, donations should be officially accepted by the granted institution and fully documented together with an allocation affirmation. Such funds may under no circumstances be transferred to private accounts.

### **Conflicts of interest**

Conflicts of interest can be defined as any situation in which inconsistency between the interests of a person arises in connection with the performance of his or her duties. Such competing interests can make it difficult for a person to fulfill his or her duties impartially. It can be also defined as any situation in which an individual, corporation or their relatives are in a position to exploit a professional or official capacity in some way for their personal or corporate benefit. Our suppliers do their best to fulfill their duties reliably and not to harm the goodwill of a company. They avoid situations that can lead to a conflict of interest

### **Confidentiality and data protection**

Supplier adheres to data protection principles. Its employee are responsible for protection of entrusted data.

### **Probity towards people outside the company**

All people outside the company, e.g. clients, suppliers, competitors shall be treated in a respectful and proper manner. One shall restrain from using unreal, misleading or offending expressions towards the third parties. Supplier treats business partners in a rightful way, and puts quality of their products and services as a base for business relations.

### **Health and safety**

Supplier places great emphasis on ensuring proper working conditions and health and safety for all employees. The company takes necessary steps aimed at identification and prevention of potential occupational hazards, including constant assessment and improvement of working area to reduce risk.

### **Environment**

Supplier is actively involved in environmental protection and sustainable development of reduction of negative environmental impact reduction in its locations. It shall perform regulatory compliance both related to operating in countries and its internal procedures and rules.

### **Third party rights**

The Supplier when manufacturing components for Fideltronik must not infringe the rights of third parties (e.g., work on illegal software, stolen equipment or technologies).

**The provisions of Code of Conduct are presented to every supplier.** Fideltronik expects proper business communication and cooperation free from intentions and actions aimed at corruption and bribery. In case of infringement of the code of conduct rules, Fideltronik has a right to execute liabilities from suppliers. The method and scope of sanction depends upon the degree of code violation, as well as legal obligations.

## **10.4 HEALTH AND SAFETY OF WORK**

The management of Fideltronik recognizes that the life, health and safety of employees is very important, and therefore makes every effort to provide them with safe and hygienic working conditions. The same is required of Fideltronik's Business Partners, in particular:

1. Preventing accidents, occupational diseases and other near misses through regular inspections of working conditions, carrying out risk analysis and implementing appropriate actions. The participation and commitment of employees should be important in these activities.
2. Activities in relation to compliance with the legal regulations and other requirements applicable in the course of the business.
3. Allocating the necessary resources and funds for the implementation of programs and tasks to achieve health and safety goals.

## 10.5 CONFIDENTIALITY AND INTELLECTUAL PROPERTY RIGHTS

### Confidentiality

Confidential Information shall include any and all information regarding Fideltronik, its business partners and associated entities, in particular any information of technical, technological, legal, commercial or organizational nature, as well as information regarding their products, strategies, personnel, finances or future plans or perspectives obtained by the Supplier in written, electronic or oral form (hereinafter referred to as "the Confidential Information"). The Confidential Information includes in particular data contained in technical documentation, documents and draft of documents obtained from Fideltronik.

Information remains confidential regardless whether it has been marked with the clause "confidential", "secret" or any other clause equivalent to the above mentioned ones.

As confidential information shall not be considered:

- information that is publicly available (however not as a consequence of violation of the terms and conditions of the present Agreement by the Supplier) or
- information on which the Parties agreed in writing that it may be disclosed.

Confidential Information constitutes Fideltronik's trade secret within the meaning of the provisions regarding combating of unfair competition, and its disclosure may, apart from the consequences provided for in the present Agreement, bring about the consequences provided for in the relevant provisions regarding combating of unfair competition as well as in the provisions regarding the protection of intellectual property.

### Intellectual Property

Intellectual property rights or other information related to the design of the Products, including specifications, as well as any software, products or inventions related to the Products provided to the supplier are the exclusive property of Fideltronik or its customers.

Supplier may use the Project Information and any related intellectual property rights required to provide services, manufacture and supply products for the duration of the applicable Purchase Agreement (unless otherwise specified in another agreement).

The Supplier warrants and represents that the Design Information and any related intellectual property rights and the production and delivery of the Products will not infringe any third party rights, including intellectual property rights.

## 11 SHIPPING OF GOODS AND INVOICES

### Receipt of goods

Independent of delivery terms, the supplier of the transport service is obliged to check the quality and correctness of goods in the place of loading.

Every nonconformance noticed by the hauler should be documented and communicated to the transport service contractor.

In the case of goods being noticed as damaged or wrongly protected for delivery, the forwarder is obliged to report his doubts and remarks to the contracting service.

### Shipping conditions and compliance with documents

The supplier is obliged to forward to the hauler goods which meet the following requirements:

1. the quantity of packets handed over is the same as the amount shown in the bill of lading
2. description on packaging conforms with details on the bill of lading
3. goods are imposed a customs duty - concerns imported materials
4. packages are original and not damaged (there are no signs of flooding or opening)
5. the delivery note contains the ASN number (Advance Shipping Notice)
6. documents must always be outside the packaging, accessible without it opening.

The carrier has the right to verify above points before leaving the place of loading.

### Damaging of goods during transport

If, while checking the condition of the parcel, some visible and outside damage is noticed, with no protocol written down at a place of loading, the carrier takes the responsibility for damaging the parcel.

In the place of unloading a damage protocol should be written down, this is a base for claims to the supplier of the transport service.

Damage during transport resulting from wrong packing of material (where there is no visible outside damage of multipacks or components) is not subject to the transport company complaint. In this case the side responsible for the way it was packed bear the responsibility.

### Special requirements concerning transport

In case of chemicals - where Material Safety Data Sheet describe specific conditions of storage - and other products determined by Fideltronik, the hauler is required to monitor the temperature and humidity conditions during transport, documenting them and making them available at Fideltronik request.

Goods cannot be picked up from the carrier if the special requirements were not fulfilled.

### Additional, suppliers of materials are obliged to follow the principles as below:

- wherever it is required to provide a Material Safety Data Sheet
- during transport and unloading of dangerous materials the supplier has to have knowledge of how to pack them, how they act on human organisms and how to proceed when wrap is broken
- to use transport methods suitable for the carriage of substances according to their specification
- hazardous materials must be clearly marked and must have labels in polish as well
- the weight of a single package should not be more than 25 kg
- the maximum weight of a pallet with commodity is 800 kg, maximum height 170 cm

### Important:



Fideltronik reserves the right not to collect goods that have not been ordered.

### Suppliers of services to Fideltronik are obliged to:

- perform Health and Safety, fire protection and potential risks training courses. These training courses are carried out by FT staff.
- follow the instructions of security personnel employed by Fideltronik
- comply with instruction concerning residing and driving on Fideltronik premises
- moving around the premises in areas in accordance with the service provided
- informing about accidents
- using protective/working clothing that is in line with service provided
- using functioning technical equipment
- fulfill national electrical safety certification requirements (e.g SEP)- ensure that modes of transport are in good technical condition
- assure proper storage of items
- properly mark (Identification and properties) of chemical substances used
- follow general health and safety regulations
- comply with rules relating to the transfer of cargo with regards to manual handling
- inform Fideltronik about the premium freight (extra costs or charges incurred additional to contracted delivery)
- suppliers providing services on the premises of Fideltronik are the owners of the waste generated, and thus are responsible for waste management in accordance with the relevant health and safety regulations and legal requirements unless otherwise specified in a separate Agreement.

### Sending Invoices

Invoices for supplied materials or services must be successfully delivered to Fideltronik in the following way:

- Electronic method through EDI, RosettaNet or
- Electronic method through ISupplier or
- Normal mail or courier to the address:

FIDELTRONIK POLAND SP.Z.O.O.  
BENIOWSKIEGO 1  
34-240 SUCHA BESKIDZKA  
POLAND  
VATIN: PL5521298418

Payment for the delivered goods or services is possible only if the invoice has been successfully delivered and is consistent with the order.

## 12 PACKAGING

### General rules of packing

1. The size of the package must be adapted for the contents of the shipment in order to minimize free spaces inside the package.
2. The strength of the package should be adapted to the weight and the shape of the contents. There shall not be irregular carton shapes, only family size and to supplement vacancies with the filler.
3. Damaged boxes are banned from being packed in.
4. The elements intended for the dispatch should be clean greases and liquids should be removed from them.
5. If not specified otherwise one should use partitions, dividers and fillings.
6. The parcel should be described with relevant warning stickers (e.g. attention glass)
7. Putting collective labels is necessary.
8. Documents must always be outside the packaging in order to be available without opening cartons.

9. Packing components from the MSD family should be safe and adapted to the conditions prevailing in the planned transport (Road, Air, Sea) while maintaining all norms and standards.
10. Packing components from the ESDS should be in accordance with the requirements of "IEC 61340-5-1/2/3" and "ANSI/ESD S541".
11. Supplier is forbidden to use foil, bag and tape that do not meet the ESD requirements. Exception from this rule has to be approved by Fideltronik at the component quotation stage.
12. Use of polystyrene in packaging is forbidden. Exception from this rule has to be approved by Fideltronik at the component quotation stage.

## **Pallets, transport specification and requirements:**

1. Usage of only certified **EURO EPAL** pallets.
2. Usage of only non-damaged pallets.
3. Permanently fasten parcels to the pallet using stretching foil and/or tape.
4. Elements of the package do not stick out beyond the pallet. If some part of the untypical consignment sticks out beyond the edges of the pallet it must be ruthlessly wrapped up not to damage itself and/or other parcels.
5. Lighter elements (e.g. cartons) should be put on heavy elements
6. the center of gravity must be localized in parcels and the height of the parcel must be agreed with the transport service.
7. If it's possible secure all angles of the parcel with cardboard corners.
8. Arrangement of elements on a pallet must be adapted to transporting on transit routes of standard EURO EPAL. 2. pallet width.

The sender is responsible for the quality of wrapping up of the parcel making sure it is adequate for the content.

The sender is obliged adequately to wrap up the parcel, as well as giving it to the courier in a state enabling its correct transport and assuring that it won't damage other parcels during transport, as well as providing it without loss and damage.

Particularly the package should: be appropriately closed, preventing unauthorized persons the access to the contents of the parcel; be appropriately tough in accordance to the weight and contents; have internal safety barriers preventing the movement of content; have markings attesting to special character of the parcel, such as: „ attention, glass ”, „ top/bottom ”

## **12.1 REQUIREMENTS CONCERNING THE IDENTIFICATION ON PACKAGES**

**The preferred label by Fideltronik is the 2D version as per the below example.**

Detailed specification of such label "2D labels specification" is attached as the separate document on Fideltronik website: <https://fideltronik.com/new-supplier/>

**Sample of correct 2D label / Proposed dimensions: 6cm x 4,5 cm**



**If the Supplier is unable to print a 2D label, Fideltronik may conditionally accept labels in accordance with the guidelines below, provided that as part of the development of cooperation, they will be replaced with 2D labels.**

**1. Single-product wrappings must hold:**

- Fideltronik Order Number (with the release & line number)
- Fideltronik Item Number (barcode Code-128 + text below the barcode)
- Fideltronik Item Revision (barcode Code-128 + text below the barcode)
- Fideltronik Item Description
- Manufacturer Name with identification of production plant (if there is more than one)
- Manufacturer Part Number MPN (barcode Code-128 + text below the barcode)
- Reference Number of Manufacturer – date code (YYWW) (bar + label) and lot code (bar + label)
- Quantity in a single package (barcode Code-128 + text below the barcode)

Moreover, if it is possible:

- Confirmation of RoHS and/or REACH compliance

**2. Collective wrappings must hold:**

- ASN Number (barcode Code-128 + text below the barcode)
- or:
- Fideltronik Order Number (with the release & line number)
- Fideltronik Item Number (barcode Code-128 + text below the barcode)
- Fideltronik Item Revision (barcode Code-128 + text below the barcode)

- Fideltronik Item Description
- Manufacturer Name with identification of production plant (if there is more than one)
- Manufacturer Part Number MPN (barcode Code-128 + text below the barcode)
- Reference Number of Manufacturer – date code (YYWW) (bar + label) and lot code (bar + label)
- Quantity in collective package (barcode Code-128 + text below the barcode)





Moreover, if it is possible:

- Confirmation of RoHS and/or REACH compliance

**Additionally Supplier shall put information regarding the weight of single and collective wrapping. Such information shall be placed visibly for a controller**

**Samples of correct labels / Proposed dimensions: 70mm X 50mm**

1. Single-product wrappings

<b>Fideltronik Order Number</b> <b>1234567</b>	
<b>Fideltronik Item Number</b>  <b>M1FT00001</b>	<b>Fideltronik Item Revision</b>  <b>001</b>
<b>Fideltronik Item Description</b> <b>DESCRIPTION</b>	
<b>Manufacturer Part Number</b>  <b>1234567DD88</b>	<b>Manufacturer Name</b> <b>MANUF. NAME</b>
<b>Reference Number of Manufacturer</b>  <b>11041234567890</b>	<b>Confirmation of RoHS</b> <b>Quantity in the unit package</b>  <b>10000</b>

2. Collective wrapping

<b>Fideltronik Order Number</b> 1234567	<b>ASN Number or Order Number</b>  1234567890
<b>Fideltronik Item Number</b>  M1FT00001	<b>Fideltronik Item Revision</b>  001
<b>Fideltronik Item Description</b> DESCRIPTION	
<b>Manufacturer Part Number</b>  1234567DD88	<b>Confirmation of RoHS</b>
<b>MANUFACTURER NAME</b>	<b>Quantity in the unit package</b>  1000
<b>Reference Number of Manufacturer</b>  11041234567890	<b>Quantity in collective package</b>  10000

## REQUIREMENTS IN RELATION TO PARTICULAR GROUPS OF COMPONENTS

### 13 CATALOGUE COMPONENTS

(electronic, chemical and mechanical)

#### Person responsible for product / service quality

The supplier shall be obliged to appoint a person responsible for quality of the supplied products and services. Such person should:

- have the necessary authorisations to be able to represent the supplier during quality talks with Fideltronik
- provide necessary support and aid in solving quality problems

#### Certificate of compliance

Fideltronik can require a certificate of compliance to the first shipment and to every consecutive shipment if it was specified in technical specification (point CoC=Yes).

In case of such requirement Certificate of Compliance shall be send in electronic version to the following e-mail :

[coc@fideltronik.com](mailto:coc@fideltronik.com) – location in Cracow

[coc.sucha@fideltronik.com](mailto:coc.sucha@fideltronik.com) – location in Sucha Beskidzka

For other Fideltronik locations paper format applies.

Certificate of compliance should contain at least the following information:

- ◆ Manufacturer Name
- ◆ Full manufacturing symbol (PART NUMBER)
- ◆ Production Date of the elements supplied, e.g., in the form WW/YY (week/year)
- ◆ Manufacturer's request number (LOT / BATCH)
- ◆ Fideltronik Item Number
- ◆ Fideltronik Order Number and quantity on the Order
- ◆ Quantity supplied
- ◆ Confirmation that the delivery meets Fideltronik' s requirements
- ◆ Any discrepancies from FT requirements only approved by FT

#### Specific requirements

- ◆ Due to special requirements of Fideltronik customers, the supplier shall place the manufacturer's LOT / BATCH number on the compliance certificate.
- ◆ The supplier shall see to it that the Manufacturer and the Symbol of the provided elements are in compliance with the order.
- ◆ If, due to market climate, provision of an element of the specified manufacturer is not possible, Fideltronik shall be notified about it right after the receipt of an order. The supplier shall specify the proposed replacement, and Fideltronik shall give on that basis written (e-mail, fax) approval of delivery of such elements.
- ◆ Date of production of electronic elements shall be below two (2) years
- ◆ Date of production of PCB boards shall be below 6 months
- ◆ Validity period of the chemical materials shall be at least 6 months from the date of delivery. In the case of materials for which the manufacturer specifies a shorter validity period than 6 months. The validity period for use cannot be shorter than 75% of the manufacturer's specified range.
- ◆ If the production dates of the a/m elements exceed the time acceptable to Fideltronik – the supplier shall obtain from FT written consent for sale of such elements.
- ◆ Components in Ball Grid Array (BGA) packages are to be delivered to Fideltronik in the original manufacturer's packing (trays/reels), without any repacking performed by the supplier.

## 14 PRINTED CIRCUIT BOARDS

### Quality management system

The supplier is required to have a quality management system implemented and maintained based on ISO 9001 or IATF 16949.

### Specific requirements:

1. Fideltronik does not accept panels with X-out.
2. Solder mask thickness:  $10\mu\text{m} < \text{SM} < 40\mu\text{m}$  measured in the middle of copper field min 2x2mm or track with width min 0,3mm, in the potentially thickest point
3. Fideltronik does not accept double applied solder mask. Double application of solder mask requires Fideltronik approval.  
The exception are printed circuits boards with a base copper thickness  $\geq 70\mu\text{m}$ .
4. Requirements for V-cut process (unless GBR specifies otherwise):

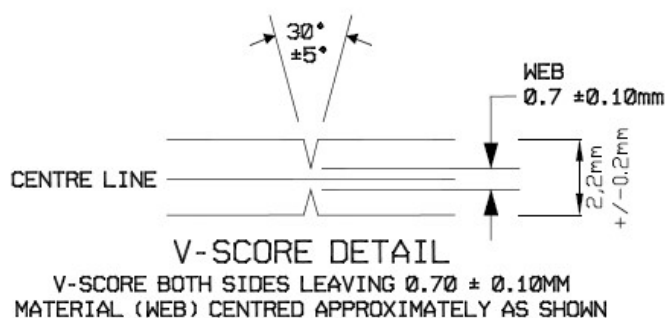
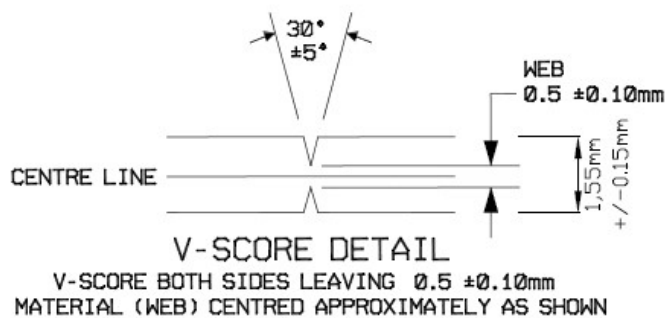

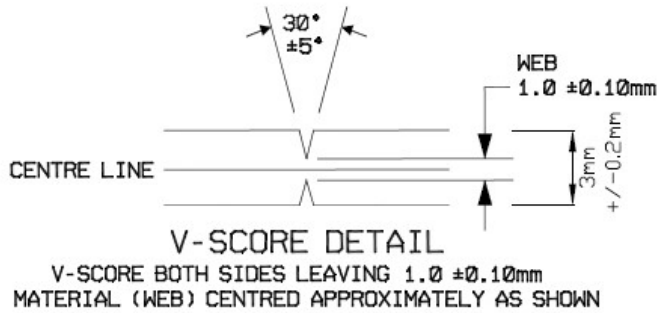

- Legend requirements (unless GBR files specify otherwise) - fields that are part of the legend and do not constitute descriptions (examples shown in the pictures below) which can be used for laser burning of barcodes by Fideltronik:

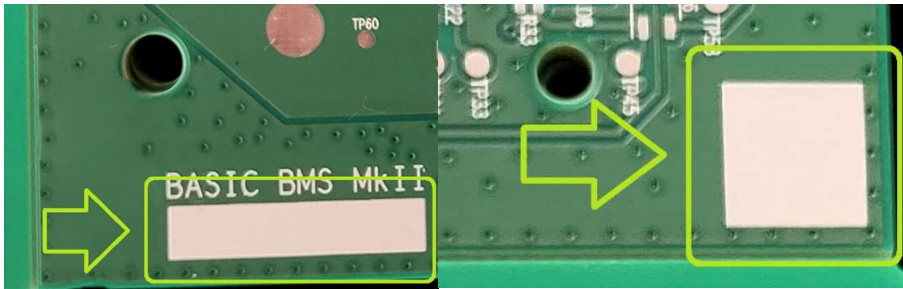

- legend thickness (silkscreen) from 0,01mm to 0,02mm
- no voids allowed

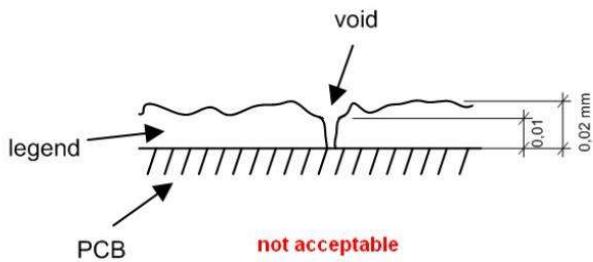
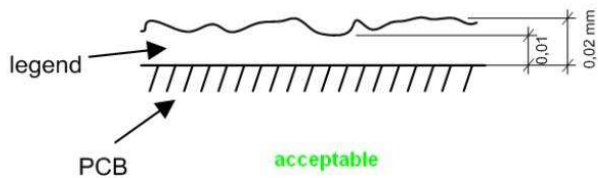



6. 'Stack up' requirements – if 'stack up' is not specified in the technical specification, it has to be agreed with Fideltronik – requires approval from Fideltronik.
7. Packaging requirements:
  - **The packaging method** must be in accordance with IPC-1602. Packaging that consists of desiccant material and a Humidity Indicator Card (HIC) sealed with the printed boards inside a Moisture Barrier Bag (MBB) is required.
  - **The quantity in a unit package** must comply with the minimum quantity in the package agreed with Fideltronik / MPQ (Minimum Packing Quantity)
8. Requirements for Surface Energy Level measurements - some of Fideltronik's products are subject to the IPC-HDBK-830 standard, therefore we require the supplier to measure the Surface Energy Level for each production batch and provide the results of these measurements at Fideltronik's request.

In case when Fideltronik Customer requirements are different than Fideltronik, supplier shall apply the more restrictive to meet both (Fideltronik Customer and Fideltronik requirements).

### **Important:**

Any modifications by the supplier in Gerber files or any other Customer documentation in any way, shape or form are not allowed without Fideltronik' approval.

### **Person responsible for quality of products / services**

The supplier shall be obliged to appoint a person responsible for the quality of the supplied products and services. Such person should:

- have the necessary authorisations to be able to represent the supplier during quality talks with Fideltronik, e.g., Quality Representative or Quality Manager.
- provide necessary support and supervise corrective activities and other operations connected with development of the quality management system.

### **Tests / product inspection carried out by the Supplier**

The supplier shall be obliged to carry out necessary tests and visual inspection in order to ascertain compliance with the requirements included in the product specification.

The supplier shall additionally (if the specification does not explicitly quote other quality standards):

- ◆ carry out electrical tests

Note: results of tests will be filed by the Supplier and made available to Fideltronik on request.

- ◆ carry on inspection of products for compliance with industrial standard **IPC-A-600 (the latest revision and minimum Class II)**.

### **Certificate of compliance**

Fideltronik requires a certificate of compliance to the first shipment.

Fideltronik can require also a certificate of compliance to every consecutive shipment if it was specified in technical specification (point CoC=Yes).

It is required to send the certificates in electronic version to the following e-mail :

[coc@fideltronik.com](mailto:coc@fideltronik.com) – location in Cracow

[coc.sucha@fideltronik.com](mailto:coc.sucha@fideltronik.com) – location in Sucha Beskidzka

For other Fideltronik locations paper format applies.

Certificate of compliance should contain at least the following information:

- ◆ Fideltronik Item Number
- ◆ Fideltronik Order Number and quantity of the Order
- ◆ Quantity supplied
- ◆ Information about materials used (manufacturer, symbols, etc.)
- ◆ Confirmation that the products passed all the required tests and measurements at the Supplier's
- ◆ Production Date of delivered parts, e.g., in the form WW/YY (week/year):  
**Note:** On the day of delivery at Fideltronik, the Production Date cannot exceed:
  - 9 months for HASL and ENIG
  - 4 months for OSP, Immersion Tin, Immersion Silver
- ◆ Any derogation from FT requirements only with the consent of FT
- ◆ In the case of products requiring the UL symbol, the following symbols must be shown on the certificate:  
-UL RECOGNITION and the E-FILE number

### Compliance with UL requirements

In the case of printed boards that require the UL symbol (specified in Fideltronik's technical documentation), the supplier is obliged to confirm compliance with UL in the certificate and include the necessary information on the board (UL symbol, etc.).

The following information is required:

<ul style="list-style-type: none"><li>◆ the UL RECOGNITION symbol</li><li>◆ the DESIGNATION type</li><li>◆ the class of combustibility (e.g. UL 94-V0)</li><li>◆ manufacturer's logo</li><li>◆ date of production</li></ul>	
---	---

## 15 MAGNETIC COMPONENTS

### Quality management system

The supplier is required to have and maintain a quality management system based on ISO 9001 IATF 16949 or at least the following procedures of ISO 9001:

- ◆ documentation supervision
- ◆ records supervision
- ◆ supervision of faulty products
- ◆ identification and traceability in the production process
- ◆ corrective actions

### Person responsible for quality of products / services

The supplier shall be obliged to appoint a person responsible for the quality of the supplied products and services. Such person should:

- have necessary authorisations to be able to represent the supplier during quality talks with Fideltronik, e.g., Quality Representative or Quality Manager
- provide necessary support and supervise corrective activities and other operations connected with development of the quality management system.

### Tests carried out by the Supplier

Fideltronik requires that the supplier carries out electrical and insulation tests (100% of the supplied batch) in order to ascertain that the product parameters are kept.

Note: Test results will be filed by the Supplier and made available to Fideltronik on request.

### Certificate of compliance

Fideltronik requires a certificate of compliance to the first shipment.

Fideltronik can require also a certificate of compliance to every consecutive shipment if it was specified in technical specification (point CoC=Yes).

It is required to send the certificates in electronic version to the following e-mail :

[coc@fideltronik.com](mailto:coc@fideltronik.com) – location in Cracow

[coc.sucha@fideltronik.com](mailto:coc.sucha@fideltronik.com) – location in Sucha Beskidzka

For other Fideltronik locations paper format applies.

Certificate of compliance should contain at least the following information:

- ◆ Fideltronik Item Number
- ◆ Fideltronik Order Number and quantity on the Order
- ◆ Quantity supplied
- ◆ Information about materials used (manufacturer, symbol, etc.)
- ◆ Confirmation that the products passed all the required tests and measurements at the Supplier's
- ◆ Date of production, e.g., in the form WW/YY (week/year)
- ◆ Any discrepancies from FT requirements only approved by FT
- ◆ In the case of products requiring the UL symbol, the following symbols must also be shown on the certificate:
  - UL RECOGNITION and the E-FILE number
  - Magnetic requirements with the UL symbol

### Compliance with UL requirements

For magnetic levels requiring the UL symbol (specified in Fideltronik's technical documentation), the supplier is obliged to confirm compliance with UL in the certificate and include the necessary information on the product (UL symbol, etc.).

## 16 LOOMS

### Quality management system

The supplier is required to have and maintain a quality management system based on ISO 9001 or IATF 16949 or at least the following procedures:

- ◆ documentation supervision
- ◆ records supervision
- ◆ supervision of faulty products
- ◆ identification and traceability in the production process
- ◆ corrective actions

### Person responsible for quality of products / services

The supplier shall be obliged to appoint a person responsible for the quality of the supplied products and services. Such person should:

- have the necessary authorisations to be able to represent the supplier during quality talks with Fideltronik, e.g., Quality Representative or Quality Manager.
- provide necessary support and supervise corrective activities and other operations connected with development of the quality management system.

### Tests, measurements and criteria for product's visual inspection

The supplier shall be obliged to carry out necessary tests and visual inspection in order to ascertain compliance with the requirements included in the product specification.

The supplier shall additionally (if the specification does not explicitly quote other quality standards):

- ◆ take samples of clamped cables and measure the stripping force of the clamp tips at start up, in progress and at the end of the clamping process. The measurements must be made for each type of clamped tips. Minimum stripping force is defined in the standard **PN-EN 60352-2**.

Note: Test results will be filed by the Supplier and made available to Fideltronik on request and quoted in the Certificate of Compliance for each batch.

- ◆ inspect the products for compliance with the industrial standard **IPC-A-620 Class II**.

### Certificate of compliance

Fideltronik requires a certificate of compliance to the first shipment.

Fideltronik can require also a certificate of compliance to every consecutive shipment if it was specified in technical specification (point CoC=Yes).

It is required to send the certificates in electronic version to the following e-mail :

[coc@fideltronik.com](mailto:coc@fideltronik.com) – location in Cracow

[coc.sucha@fideltronik.com](mailto:coc.sucha@fideltronik.com) – location in Sucha Beskidzka

For other Fideltronik locations paper format applies.

Certificate of compliance should contain at least the following information:

- ◆ Fideltronik Item Number
- ◆ Fideltronik Order Number and quantity on the Order
- ◆ Quantity supplied
- ◆ Confirmation that the products passed all the required tests, measurements and an inspection in accordance with the standards indicated in 6.3
- ◆ Date of production, e.g., in the form WW/YY (week/year)
- ◆ In the case of products requiring the UL symbol, the UL RECOGNITION and the E-FILE number of particular cables and insulation mantles must be additionally shown on the certificate.

### Compliant with UL requirements

The supplier is obliged to place the necessary UL information in CoC and on the product (UL symbol, etc.)

## 17 ELECTRO-MECHANICAL AND MECHANICAL COMPONENTS

### Quality Management System

The supplier is required to have a quality management system implemented and maintained based on ISO 9001 or IATF 16949 or at least the following procedures:

- ◆ supervision of the documentation
- ◆ supervision of records
- ◆ supervision of faulty products
- ◆ identification and traceability in the production process
- ◆ corrective actions

### Person responsible for quality of products / services

The supplier shall be obliged to appoint a person responsible for the quality of the supplied products and services. Such person should:

- have the necessary authorisations to be able to represent the supplier during quality talks with Fideltronik, e.g., Quality Representative or Quality Manager.
- provide necessary support and supervise corrective activities and other operations connected with development of the quality management system.

### Tests, measurements and criteria of product's visual inspection

The supplier shall be obliged to carry on necessary tests and visual inspection in order to ascertain compliance with the requirements included in the product specification.

The supplier shall additionally (if the specification does not explicitly quote other quality standards):

- Mechanical measurements (random sample control of all sizes and other parameters like shape discrepancies, surface roughness, protective coating used, type of material according to the supplied documentation)

Note: results of the tests will be filed by the Supplier and made available to Fideltronik on request.

### Certificate of compliance

Fideltronik requires a certificate of compliance to the first shipment.

Fideltronik can require also a certificate of compliance to every consecutive shipment if it was specified in technical specification (point CoC=Yes).

It is required to send the certificates in electronic version to the following e-mail :

[coc@fideltronik.com](mailto:coc@fideltronik.com) – location in Cracow

[coc.sucha@fideltronik.com](mailto:coc.sucha@fideltronik.com) – location in Sucha Beskidzka

For other Fideltronik locations paper format applies.

Certificate of compliance should contain at least the following information:

- ◆ Fideltronik Item Number
- ◆ Fideltronik Order Number and quantity on the Order
- ◆ Quantity supplied
- ◆ Confirmation that the products passed all the required tests, measurements and an inspection in accordance with the standards indicated in 7.3.
- ◆ Date of production, e.g., in the form WW/YY (week/year)
- ◆ In the case of products requiring the UL symbol (the requirement quoted in product specification), the UL RECOGNITION symbol must be additionally shown on the certificate.

## 18 FINAL PROVISIONS

These Supplier Manual, any agreement and any Fideltronik' s Order shall be governed by Polish law.

All disputes which may arise in relation to these Supplier Manual, any agreement and any Order realization from Fideltronik shall be a subject to jurisdiction of Polish courts and shall be resolved by a Polish common court materially competent for the registered office of FIDELTRONIK.

Prepared by:  
**Wioleta Śmiech**  
Supplier Quality Manager

Approved by:  
**Ryszard Iciek**  
Procurement Director

Signature: \_\_\_\_\_

Signature: \_\_\_\_\_

